

BARON

AUTOMOTIVE ACCESSORIES SPECIALISTS

NEW
KEYCHAINS



HDKD362



HDKCF363-K

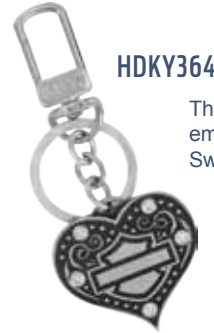

HDKY364

This design piece is embellished with Swarovski® crystals



HDKY368

Mix & Match Gift Set

4-piece keychain Gift Set. This design piece is embellished with Swarovski® crystals



HDKCF369

2-sided keychain with 3M Carbon fiber vinyl inlays

KEYCHAIN KITS

CREATE YOUR OWN KIT

24 various styles seen here inside our D25 spinning counter-top display!

Shown here is a Suggested Kit (HDKJ144DKIT) and welcome Dealer's own preferred keychain selections. Please note, keychains in kits will change every 6 months.



HDKJ144DKIT (side 1)
Sampling of 12 keychain styles shown here



HDKJ144DKIT (side 2)
Sampling of 12 keychain styles shown here



©2015 H-D or its Affiliates. HARLEY, HARLEY-DAVIDSON and the Bar & Shield Design are among the trademarks of H-D U.S.A. LLC, Baron & Baron Inc. is a licensee of Harley-Davidson Motor Company.



INTERCHANGEABLE MEDALLION KEYCHAINS EMBELLISHED WITH SWAROVSKI® CRYSTALS



HDKY12

Made with ENVIRONMENTALLY FRIENDLY MATERIALS. Stainless Steel Plain Bar and Shield keychain. This design piece is embellished with Swarovski® crystals. Emblem Size: 1-3/8" W x 1-3/8" H



HDKFSY191R

130, 2.4mm crystals protected with mini domes. Interchangeable Medallion keychain with removable clasp. Made with ENVIRONMENTALLY FRIENDLY MATERIALS. Stainless Steel Crystal Skull keychain. This design piece is embellished with Swarovski® crystals and a key ring imprinted with a laser engraved H-D® wordmark. Size: 3-7/8" L x 3/4" W.



Made with a Movable Jaw. Above close-up seen without keyring.

18" BELT LOOP FASHION KEYCHAINS



HDKMM12

For Him. An 18" long fashion keychain with dual clasps, key ring, and 3 interchangeable medallions. (M12, M14 & MS191)



Comes with Velour pouch



VELOUR POUCH

This rich black velour pouch comes with many of our interchangeable medallion keychains. A beautiful bonus.



HDKFMY12

For Her. An 18" long fashion keychain with dual clasps, key ring, and 3 interchangeable medallions. This design piece is embellished with Swarovski® crystals.



Comes with Velour pouch

Swarovski® is a registered trademark of Swarovski AG.



INTERCHANGEABLE MEDALLION KEYCHAINS



Comes with Velour pouch

HDKM188

Dual split HD® Bar font wordmark.
Medallion Size: 1.8"W x .047"H ea.



VELOUR POUCH

This rich black velour pouch comes with many of our interchangeable medallion keychains. A beautiful bonus.



Comes with Velour pouch

HDKMY12

Dual medallions. A Black filled Bar & Shield & a plain Bar & Shield. This design piece is embellished with Swarovski® crystals.
Medallion Size: 1"W x 1"H ea.

BLING KEYCHAINS EMBELLISHED WITH SWAROVSKI® CRYSTALS



HDKY14

Bar and Shield keychain. This design piece is embellished with Swarovski® crystals.
Emblem Size: 1-13/16" W x 1-1/2" H

Comes with Velour pouch



Pink Crystals



Clear Crystals



HDKCYH62

Heart shaped keychain. This design piece is embellished with Swarovski® crystals and a decorative laser imprint.
Size: 1.4"W x 2"H



HDKCYH62BKN

Heart shaped keychain. This design piece is embellished with Swarovski® crystals and a decorative laser imprint.
Size: 1.4"W x 2"H

Swarovski® is a registered trademark of Swarovski AG.



HDKD216
Custom shaped
keychain.
Size: 1.5"W x 4"H



HDKD275
Willie G skull with
dual crossed wrenches.
Size: 1.75"W x 4"H



HDKD276
Bar & Shield with
dual crossed wrenches.
Size: 1.75"W x 4"H



HDKD282
Bar & Shield with
Rivets.
Size: 1.75"W x 4"H



HDKD284
Bar & Shield with
diamond plate.
Size: 1.75"W x 4.375"H



HDKD285
Willie G imprint with
diamond plate.
Size: 1.75"W x 4"H



HDKD239
Willie G imprint.
Size:
2"W x 4.75"H



HDKD317
Willie G, flame.
Size:
1"W x 4.375"H



HDKD333
Big Industrial
design with
rivets and the
Bar & Shield.
Size: 5" x 2"



HDKD334
Six sided shield
with the 3D
Willie G skull.
Size:
4.25" x 1.625"



HDKD335
3D Red heart.
Dual inter-locking
hearts with a new
script H-D® font.
Size: 3.5" x 1.5"



HDKD336
3D Bar & Shield
with Red &
Orange flames.
Size:
3.125" x 1.75"



HDKMLF192
Size:
1.5"W x 5-1/8"H



HDKD352
Bar & Shield,
3D Fleur-de-lis.
Size: 1.5" x 4.3"



HDKD353
Industrial look,
Bar & Shield.
Size: 1.6" x 4.15"



HDKD354
Bar & Shield,
dark diamond plate.
Size: 1.53" x 4.4"



HDKQCM357
Carabiner, diamond plate,
broken H-D wordmark, B&S.
Size: 1.85" x 3.2"



HDKMS15
Size: 2.7"W x 3.25"H



HDKPFE14-K
Black Nickel finish
Size: 1.1"W x 2.8"H



HDKPF15
Size: 1.1"W x 2.8"H



HDKPFE15-K
Black Nickel finish
Size: 1.1"W x 2.8"H



HDKPT14
Size:
1.125"W x 4"H



HDKPT15
Size:
1.2"W x 3.9"H



HDKWI08
Size: 1.3"W x 2.7"H



HDKWI15
Size: 1.3"W x 2.7"H



HDKWIE14
Size: 1.3"W x 2.7"H



HDKQCM25
Carabiner keychain.
Size: 1.7"W x 6.0"L

Carabiner clip not for load bearing use.

KEYCHAINS



HDKB014
Dog Tag shaped
Bottle Cap Opener with
Bar and Shield imprint.
Size: 1-1/8"W x 4-5/8"H



HDKB0181
Dog Tag shaped
Bottle Cap Opener
with Willie G. imprint.
Size: 1-1/8"W x 4-5/8"H



HDKD14
Bar and Shield.
Emblem: 1.75"W x 1.4"H



HDKD15
Emblem Size:
1.75"W x 1.36"H



HDKD35
Live to Ride,
Ride to Live keychain.
Medallion size:
1.5" L x 1.25" H



HDKD86
Vintage Bar and Shield.
Emblem: 2"W x 1.125"H



HDKDK86
Orange & White painted
Dark Metal Vintage Bar & Shield.
Fob Size: 2.0" wide



HDKD102
Emblem size:
1.55"W x 2.25"H



HDKD103
Emblem size:
1.55"W x 2.25"H



HDKD140
Tribal design keychain.
Bar and Shield imprint.
Keychain size:
1.375"W x 3.25"H x .125"D



HDKD153
Custom shaped
keychain.
Size: 1.4" W x 4" H

SKULL KEYCHAIN



Actual size

HDK191
Moving Jaw Action!
Metal Skull keychain with
laser engraved Bar and Shield logo.
Size: 3-7/8" L x 3/4" W.



Made with a Movable Jaw.
Above close-up seen without keyring.

MULTI-FUNCTION KEYCHAINS

HDKTPF14

7-Tool keychain:
Flashlight, pliers,
bottle opener, knife, file,
phillips screw driver,
flat head screw driver
Opened Size: 2.25"W x 5.5"H



(Above, front view)

HDKTK14

Multi-tools
Bottle opener, knife,
phillips screw driver,
flat head screw driver.
Size: 1.25"W x 2.25"H



Now available
with a light!
(Back view)



HDKPL15

Projector Flashlight with a
Three Color Bar and Shield.
Size: 0.5"W x 3.25"H



Simulated projection
from Flashlight



**5 caps
in each package!**

TPMS COMPLIANT VALVE STEM CAPS WITH H-D® IMPRINTS
(5 caps in package)

Chrome Plated Plastic Valve Stem Covers for your Tires. TPMS Compliant, including inner "O" ring seal ensuring a clean valve orifice to maintain consistent tire pressure. UV-Resistant Film packaged in Hang-tab HD Box. TPMS sensor federally mandated installed all new vehicles sold after September 2007 electronically monitors air pressure. Package comes with 5 caps.



HDVC240



HDVC25



HDVC14



HDVC216W

**CREATE
YOUR OWN
KIT**

KEYCHAIN KITS

24 various styles seen here inside our D25 spinning counter-top display



HDKJ144DKIT (side 1)
Sampling of 12 keychain styles shown here



HDKJ144DKIT (side 2)
Sampling of 12 keychain styles shown here

Shown above is a Suggested Kit (HDKJ144DKIT) and welcome Dealer's own preferred keychain selections. Please note, keychains in kits will change every 6 months.



D25

Elegant POP Spinner with Universal Key locks

1. Optimizes point of purchase presentation and location
2. Convenient and practical keychain merchandising
3. 2-sided, dual doors, easy access for greater visual impact at retail level
4. 360° revolving, scratch-resistant poly-carbonite plastic
Display spins on durable steel ball bearing lazy-susan base
5. Dimensions: 7" W x 15.5" H x 5.125" D.
Case includes 24 hooks holds 144 keychains

Below are the keychains used for this kit (HDKJ144DKIT)

- | | |
|--------------|-------------|
| 1 HDKCF369 | 13 HDKD15 |
| 2 HDKD362 | 14 HDK191 |
| 3 HDKCF363-K | 15 HDKD102 |
| 4 HDKY364 | 16 HDKB014 |
| 5 HDKD275 | 17 HDKD336 |
| 6 HDKD35 | 18 HDKD216 |
| 7 HDKDK86 | 19 HDKD335 |
| 8 HDKW115 | 20 HDKD317 |
| 9 HDKD334 | 21 HDKPT15 |
| 10 HDKD284 | 22 HDKQCM25 |
| 11 HDKD354 | 23 HDKD239 |
| 12 HDKD285 | 24 HDKTPF14 |



HDKJ72DKIT
D25. w/72 Keychains
(3x 24 keychain models)



HDKJ144DKIT
D25. w/144 Keychains
(6x 24 keychain models)

2 Frames per box



License plate frame dimensions: 447mm x 147mm (HDLF16-CN seen above). China license plate dimensions: 444.5mm x 146.6mm



Packaging for dual license frames.

Front















Back



TRAILER HITCH COVERS

All hitch covers are chrome plated solid brass or Zinc and firmly bolted onto a stainless steel receiver post. Additional accessories include rubber gaskets, theft-resistant stainless steel screws, washers, & nuts.

TRAILER HITCH COVERS

 <p>HDHC06 For 2" Receivers</p> <p>Willie G Millennium Skull Chrome plated finish</p>	 <p>HDHC06A For 2" Receivers</p> <p>Willie G Millennium Skull Antique Nickel finish</p>	 <p>HDHC12 For 2" Receivers</p> <p>Black color filled engraving</p>	 <p>HDHC13 For 2" Receivers</p> <p>Raised Monotone Bar and Shield</p>
 <p>HDHC13-K For 2" Receivers</p> <p>Black Nickel plated finish Raised Monotone Bar and Shield</p>	 <p>HDHC14 For 2" Receivers</p> <p>Black color filled Bar and Shield</p>	 <p>HDHC25 For 2" Receivers</p> <p>Orange, Black & White color filled Bar and Shield</p>	 <p>HDHC58 For 2" Receivers</p> <p>Black color filled engraving</p>
 <p>HDHC86 For 2" Receivers</p> <p>3D die cast with Black color fills</p>	 <p>HDHC86-K For 2" Receivers</p> <p>Above, Orange & White painted 3D Dark Metal Vintage Bar & Shield.</p>	 <p>HDHC153 For 2" Receivers</p> <p>Red, White, Blue & Black color filled engraving</p>	 <p>HDHC216 For 2" Receivers</p> <p>Black color filled engraving</p>

TRAILER HITCH COVERS

All hitch covers are chrome plated solid brass or Zinc and firmly bolted onto a stainless steel receiver post.
Additional accessories include rubber gaskets, theft-resistant stainless steel screws, washers, & nuts.

TRAILER HITCH COVERS



HDHC240
For 2" Receivers

Black color filled engraving



HDHC275
For 2" Receivers

Above, Chrome plated 3D Willie G skull over dual crossed wrenches.



HDHC276
For 2" Receivers

Chrome plated 3D Bar & Shield over dual crossed wrenches.



HDHC290
For 2" Receivers

3D Bar & Shield on a diamond plate background



HDHCKXC325
For 2" Receivers

Exposed chrome imprint on Black coated emblem



HDHC336
For 2" Receivers

3D Bar and Shield with Red & Orange flames



HDHCEOPICY14
For 2" Receivers

Bar and Shield on a Chrome Emblem. This design piece is embellished with Swarovski® crystals (Clear).



HDHCKEOPICY14-K
For 2" Receivers

Bar and Shield on a Black Emblem. This design piece is embellished with Swarovski® crystals (Black).

HITCH COVER COMPONENTS

Additional accessories include rubber gaskets, theft-resistant stainless steel screws, washers, & nuts.

Below, images of 2 common post receivers. 2" square & mini 1.25" square.



HC: 2" post, 3 foam gaskets & Locking bolt set.
NOT FOR 1.25" POST OPENINGS

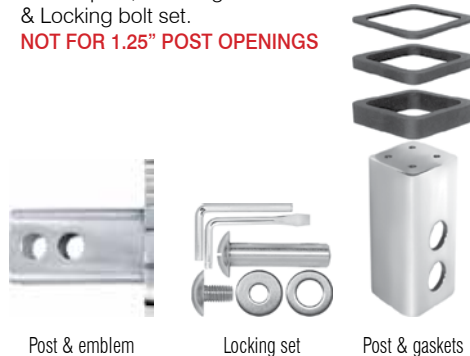

HCM: 1.25" post, 2 foam gaskets & Locking bolt set.
NOT FOR 2" POST OPENINGS

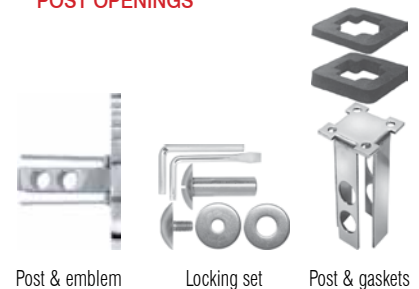

TOW BALL HITCH COVERS (HCB)

New innovative design allows hitch cover fit atop your trailer tow balls!

- Theft resistant screws
- U-Clamp fit all tow balls diameters, 47.6mm, 50.8mm, 58.7mm and those inbetween.

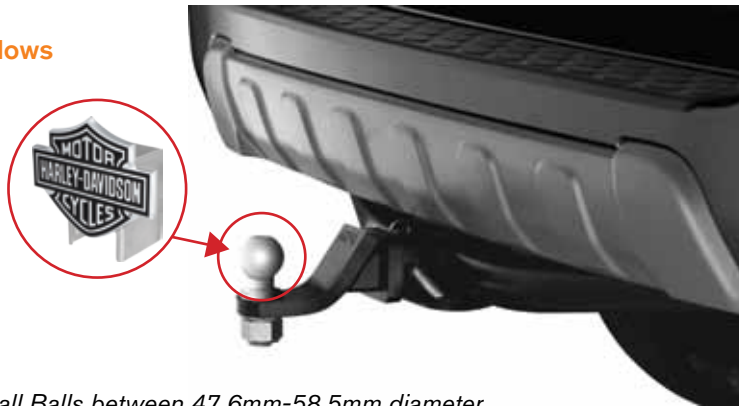

U-Clamp secures all Balls between 47.6mm-58.5mm diameter

Below 5 HCB hitch covers available primarily for all countries other than the European Union or North America



HDHCB06



HDHCB14



HDHCB25



HDHCB216



HDHCB290

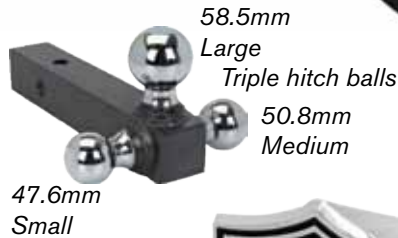
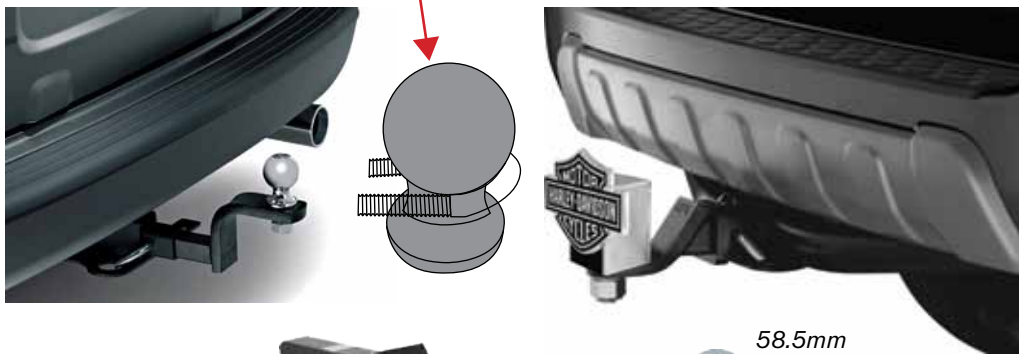

HITCH COVER COMPONENTS FOR *MOST COUNTRIES

- Innovative Tow Ball Post
- Theft resistant wrench
- Theft resistant screws
- Washers
- U-Clamp (patent pending)

*European Union vehicles has limited imported Standard Flared Hitch Balls instead vehicles outfitted primarily Swan Neck Euro Balls

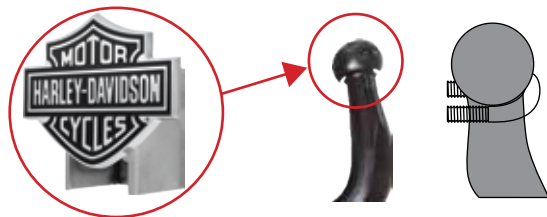

HDHCB14



HDHCB14

BARON
Automotive Accessories Specialists

15462 Electronic Lane • Huntington Beach, CA 92649-1334
Toll Free: 800-232-2766 • Fax: 714-895-5105
OR CALL (Toll Free: 877-903-3555 • Tel: 714-903-7550 • Fax: 714-903-7530)
Web Site: www.baronfi.com • E-mail: Sales@baronfi.com